

# ECE 585 Power System Stability

## Homework 1, Due on January 29

Consider the power system below. The network frequency is 60 Hz. At the pre-fault steady state (a) the power generated by the machine is 400 MW; (b) the HT voltage of the transformers is 500 kV.

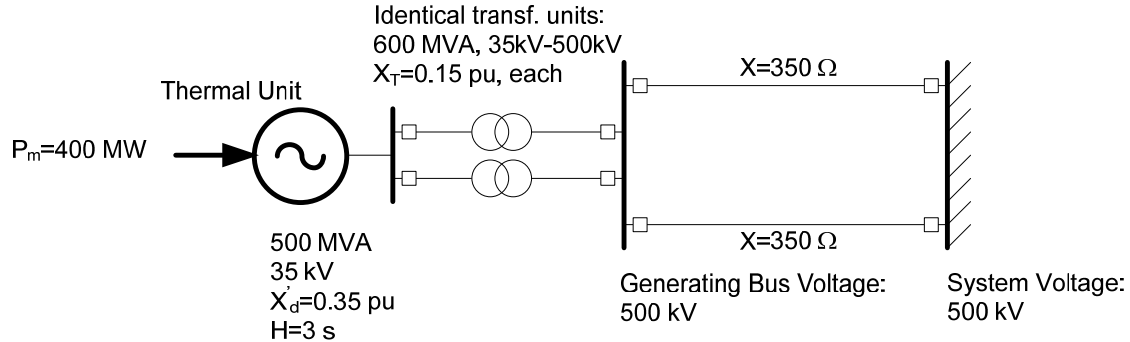

1. Determine the system load flow before the fault. Find the internal voltage and rotor angle of the machine.
2. Write in pu the motion equations of the machine.
3. A three-phase bolted fault occurs on one of the transmission circuits near the generator bus. Determine by the equal area criterion the maximum (critical) clearing time for first swing stability.

# ECE 585 Power System Stability

## Homework 2, Due Feb 5

The three-bus two-machine power system below operates at steady state with all bus voltages at 1 pu, constant. The machine data are shown in the figure, where the inertia constants are referred to the system power base.

The disturbance considered is a three phase bolted fault on one of the circuits of the line between buses 1 and 0. The disturbance is cleared by opening the breakers of the faulted circuit. Assume that during the fault the power in any line is zero.

1. Calculate the pre-fault steady state of the system and the initial rotor angles.
2. Calculate the post-fault stable and unstable equilibriums.
3. Derive the system dynamic energy as function of the machine rotor angles for the post-fault system (the center of inertia does not move in this case). Draw the contour plot of the dynamic energy in the rotor angle plane.
  1. What is the rim of the stable region? What is the critical value of the dynamic energy available to the system?
  2. Where do the rotor angles lie in the angle plane at the clearing time (e.g. find the angle trajectory during the fault)?
  3. Estimate the critical values of the clearing time and the rotor angles at clearing.

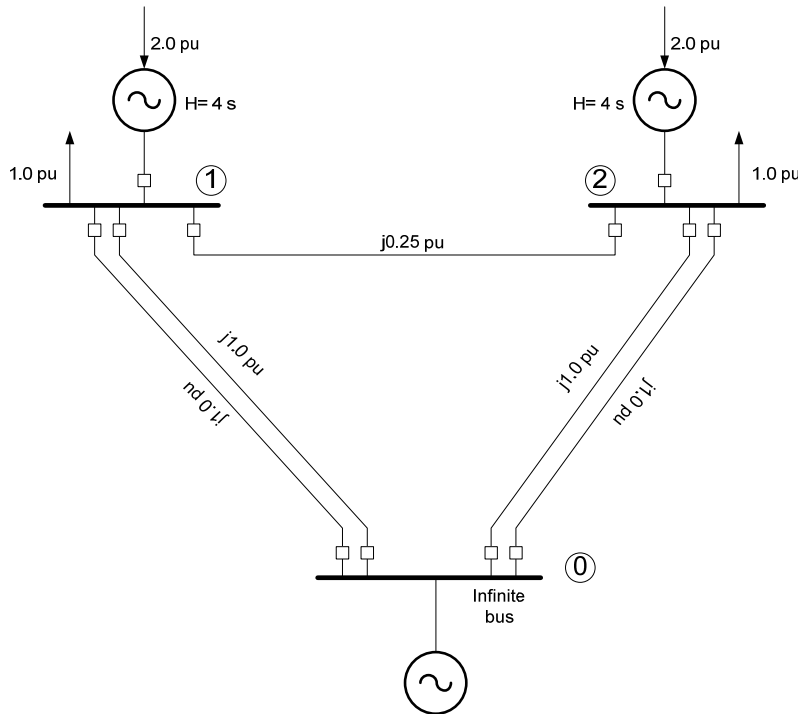

## ECE 585 Power System Stability

### Homework 3, due February 12

Problem 1 (Derivation of 0dq equ.): Derive the machine equations in the 0dq frame of reference using the transformation in (3.59) and (3.60) (Kundur). Guidance: Begin from the machine equations (3.47-3.55) written in the phase frame and derive the machine equations (3.64-3.72) written in the 0dq frame.

Problem 2 (Machine Parameters): (This problem is based on Example 3.1 from Kundur) A 500 MVA, 35-kV, 0.9-pf, 60-Hz, 3-phase, 2-pole machine has the following parameters:

$L_{aa0}=4.95$ mH	$L_{aa2}=0.07$ mH	$L_{ab0}=-2.4$ mH
$L_{ab2}=-0.07$ mH	$L_{afd}=60$ mH	$L_{ffd}=850$ mH
$L_{fkd}=50$ mH	$L_{kkd}=100$ mH	$L_{akq}=0.2$ mH
$L_{kkq}=5$ mH	$R_a=0.005$ $\Omega$	$R_{fd}=0.1$ $\Omega$
$R_{kd}=0.1$ $\Omega$	$R_{kq}=0.05$ $\Omega$	

In addition the stator leakage inductance is  $L_l=0.6$  mH.

1. Use the machine rated values as a base to calculate the pu values of the machine d and q axis parameters in the  $L_{ad}$ -reciprocal pu system.
2. Draw the machine d and q axis equivalent circuits.
3. Write the dynamic equations of the previous circuits in terms of the circuit flux.
4. At steady state, the machine delivers 500 MVA at 0.9 lagging pf (e.g. the load is lagging) and rated stator voltage. Determine the machine internal angle and electric torque. Also calculate the steady state values of all fluxes and currents on the d and q axis circuits.

## ECE 585 Power System Stability

### Homework 4, due Feb 24

Problem 1 (Machine Parameters): Consider the machine in Example 3.2 in Kundur. Derive the machine transient and sub-transient parameters on both axes as per (4.41) in Kundur. Also write the machine transfer functions in factorized form as per (4.16-18) in Kundur. Provide the Bode plot of  $L_d$  and  $L_q$ .

The machine stator is excited by a 20-Hz subsynchronous oscillation such that

$$\Delta e_d = 0.05 \cos(40\pi t) \quad \text{and} \quad \Delta e_q = \Delta e_{fd} = 0 \text{ pu.}$$

Find  $\Delta i_d$  and  $\Delta i_q$ .

Problem 2 (Machine Saturation): Repeat part c of Example 3.3 in Kundur for  $P_t=0.8$  and  $Q_t=0.4$  pu.

## ECE 585 POWER SYSTEM STABILITY

### Homework 5 SIMULATION PROJECT (Due March 17)

Write a program to simulate the dynamic equations of the machine flux model in MATLAB (including the motion equations). Integrate the equations using the trapezoidal integration rule. Include calculation of the machine steady state and state variable initialization. Write three separate routines for different complexity models:

- (a) To simulate the complete model including the stator dynamics (e.g. the transformer terms  $\dot{\psi}_d, \dot{\psi}_q$ ).
- (b) To simulate the reduced order model by neglecting the transformer terms (e.g.  $\dot{\psi}_d = \dot{\psi}_q = 0$ ).
- (c) To simulate the reduced order model by additionally neglecting the amortisseurs of the machine.

Simulate the system in Fig. 5.1 of Kundur using successively models (a), (b) and (c) above. Compare the results for the stator currents, excitation field, electric torque and rotor angle. Assume that before the fault, the machine delivers 1 pu power at 0.8 lagging power factor and 1 pu stator voltage.

## ECE 585-3, Power System Stability

Mid-Term Exam (Take Home. Due on Tuesday March 24 at 3:30 P in class)

A 500-MVA, 35-kV, 60-Hz synchronous generator is equipped with an alternator-supplied controlled-rectifier excitation system. The machine pu values are given as (note that the time constant is given in s, not in pu):

$$X_d = 1.8, X_q = 1.7, X'_d = 0.25, R_a = 0, T'_{do} = 7 \text{ s}$$

The voltage at the terminals of the ac exciter is maintained at 1.3 pu. An automatic voltage regulator is used to maintain the output bus voltage,  $E_o$ , at 1 pu. The regulator time constant is  $T_r=3$  s.

First consider the excitation system in the manual mode of operation. Determine the firing angle of the thyristors if the voltage at the output bus is 1 pu under the following conditions:

1. No load;
2. 1 pu (MVA) at 0.8 lagging power factor. Draw the two axis circuit of the machine. Calculate the machine torque and d-q axis stator currents, and d and q axis fluxes.

Next switch the excitation system to the automatic voltage regulation mode.

- (a) Use the IEEE AC4A model to represent this excitation system for incremental variations of the variables.
- (b) Calculate the gain  $K_A$  for loading condition 1 above.
- (c) Calculate the closed-loop transfer function  $\frac{\Delta E_o}{\Delta V_{ref}}$  for the same loading condition (neglect the machine amortisseurs and the motion equations).
- (d) Plot the poles of the above transfer function in terms of the gain  $K$  of the AVR (use MATLAB and the root locus tools). Find the critical value of  $K$ .

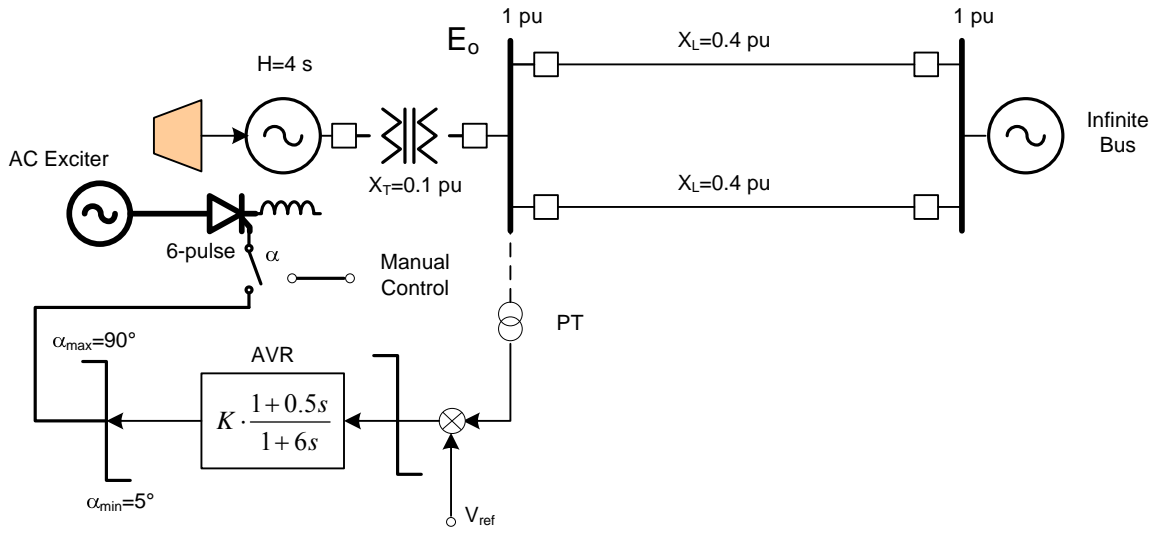

## ECE 585 POWER SYSTEM STABILITY

Homework 6 Small Signal Stability. Due on March 31.

P1 (State Equations): Consider the linear system below.

$$\begin{bmatrix} \dot{x}_1 \\ \dot{x}_2 \end{bmatrix} = \begin{bmatrix} -1 & 0 \\ -1 & -2 \end{bmatrix} \cdot \begin{bmatrix} x_1 \\ x_2 \end{bmatrix}$$

- (a) Find the state matrix eigenvalues and eigenvectors.
- (b) Find the initial conditions such that only the mode corresponding to the smallest eigenvalue is excited.
- (c) If the initial conditions are given as  $x(0) = [1 \ 1]^T$ , find the mode solution, find the solution for  $x$ , plot the solution on the phase plane ( $x_1$ - $x_2$ ).
- (d) Find the participation factor for this matrix.

P2 (Classical Stability): Consider the single-machine infinite-bus system below. At the steady state the machine generates 1 pu of real power, while the transformer secondary voltage is at 1 pu.

Find the system equilibrium and characterize its stability. Use the classical machine model with  $X'_d = 0.3 \text{ pu}$  and  $K_D = 6 \frac{\text{pu Nm}}{\text{pu rs}^{-1}}$ .

Draw the root locus of the system eigenvalues with respect to the synchronizing torque coefficient.

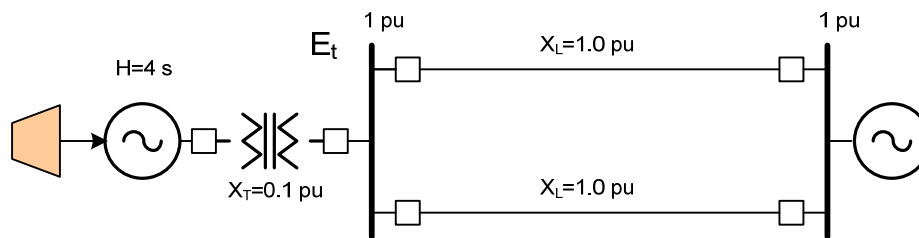

## ECE 585 POWER SYSTEM STABILITY

### Homework 7 Small Signal Stability. Due April 7.

Consider the power system below based on Kundur, example 12.3. The generator is rated at 500 MVA, 34 kV and has the following parameters:

$$L_{adu} = 1.75, L_{aqu} = 1.65, L_{\ell} = 0.2, R_a = 0, R_{fd} = 0.0005, L_{fd} = 0.16 \text{ pu.}$$

The saturation parameters are as follows:  $A_{sat} = 0.035, B_{sat} = 6.5, \psi_{T1} = 0.8 \text{ pu.}$

At the steady state, the machine generates 1 pu of real power and the voltage at the station bus is maintained at 1 pu.

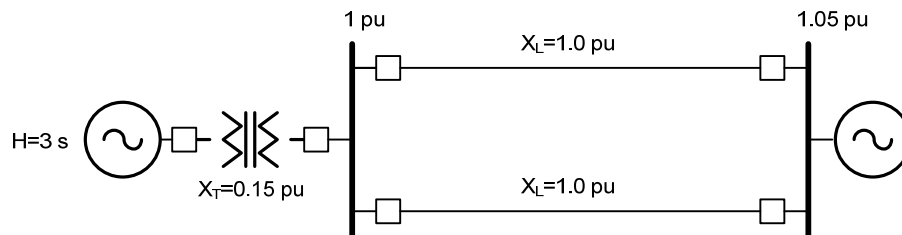

Neglect the machine amortisseurs but include the field effects.

- (a) Obtain the operating point of the system and initialize the machine variables (use  $\psi_{fd}$  as the state variable of the field and  $E_{fd}$  as the field input).
- (b) Derive the small signal model of the system around the steady state operating point. Find the model sensitivities  $K_1$  to  $K_4$ . Draw the block diagram. Also write the state equations of the system and calculate the state matrix. What are the eigenvalues?
- (c) Draw as function of the frequency (of the rotor oscillations) the synchronizing and damping torque coefficients contributed by the field action.

You may use MATLAB for the calculations.

## ECE 585 POWER SYSTEM STABILITY

### Homework 8 Small Signal Stability-Excitation Effects. Due April 14.

Consider the power system below based on Kundur, example 12.3 and section 12.4 discussion. The generator is rated at 500 MVA, 34 kV and has the following parameters:

$$L_{adu} = 1.75, L_{aqu} = 1.65, L_\ell = 0.2, R_a = 0, R_{fd} = 0.0005, L_{fd} = 0.16 \text{ pu.}$$

The saturation parameters are as follows:  $A_{sat} = 0.035, B_{sat} = 6.5, \psi_{T1} = 0.8 \text{ pu.}$

The machine is equipped with a thyristors-type ac exciter.

At the steady state, the machine generates 1 pu of real power and the voltage at the station bus is maintained at 1 pu.

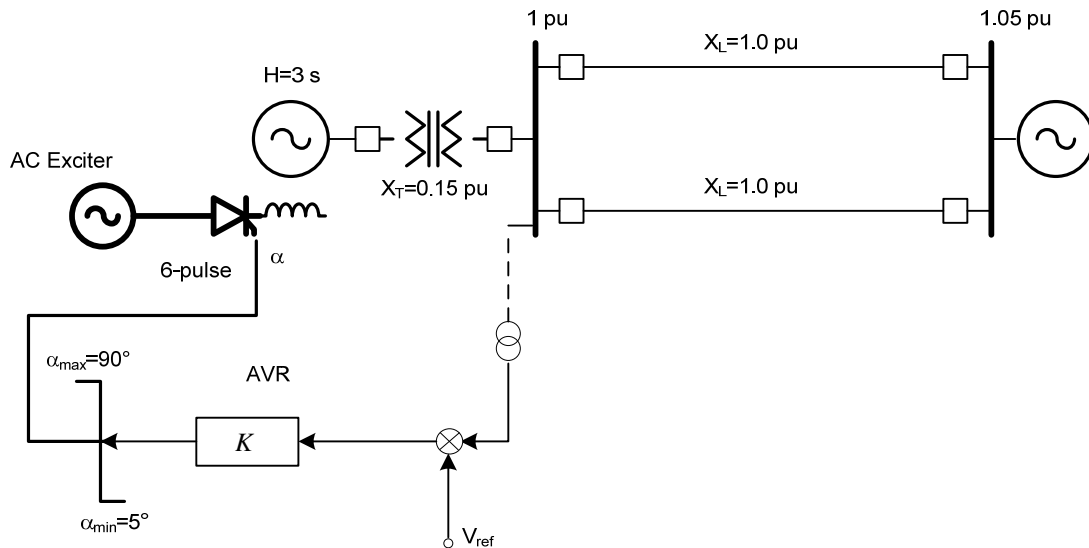

Neglect the machine amortisseurs but include the field effects. Assume that the response delay of the AVR-exciter system is negligible, and call  $K_A$  the combined forward incremental gain of the loop (e.g. from the voltage error to  $E_{fd}$ ).

- Obtain the operating point of the system and initialize the machine variables (use  $\psi_{fd}$  as the state variable of the field and  $E_{fd}$  as the field input).
- Derive the small signal model of the system around the steady state operating point. Find the model sensitivities  $K_1$  to  $K_6$ . Draw the block diagram.
- Vary the value of  $K_A$  from 0 to 1000 (as per table 12.1 in Kundur) and for each value obtain (1) the rotor frequency; (2) the synchronizing torque coefficient at the rotor frequency; and (3) the damping torque coefficient at the rotor frequency. Draw conclusions.

You may use MATLAB for the calculations.